

STJ-220 – Product Overview

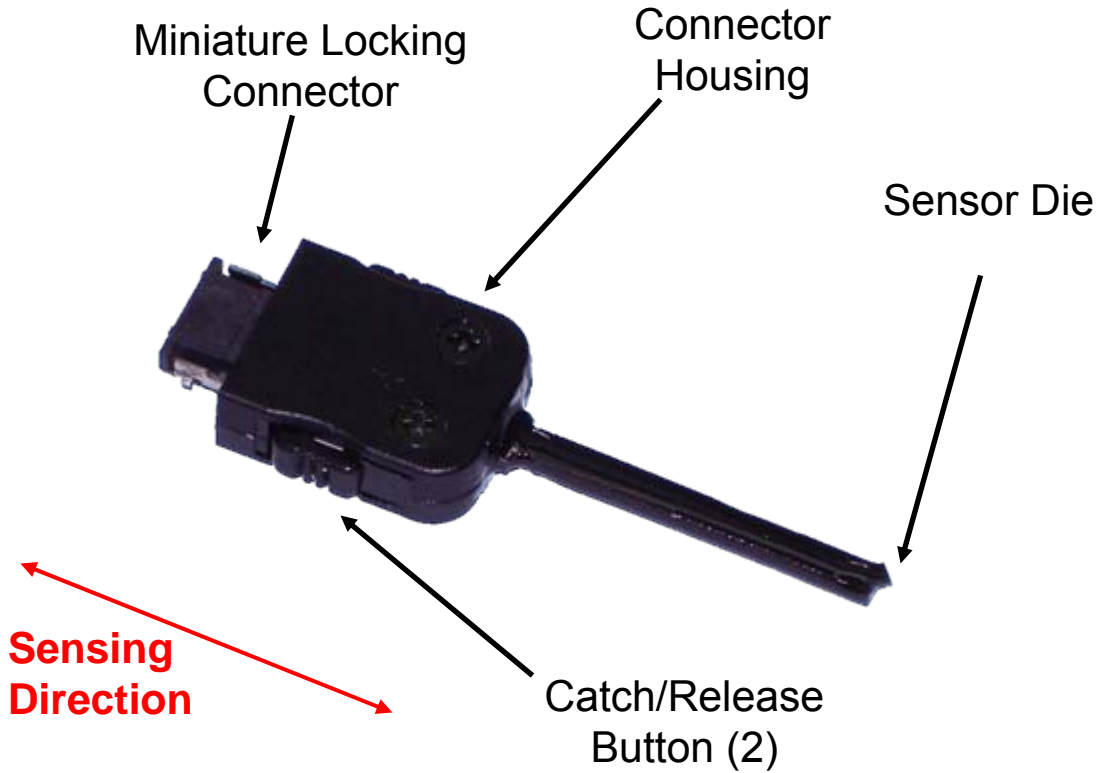

STJ-220 – Physical Dimensions

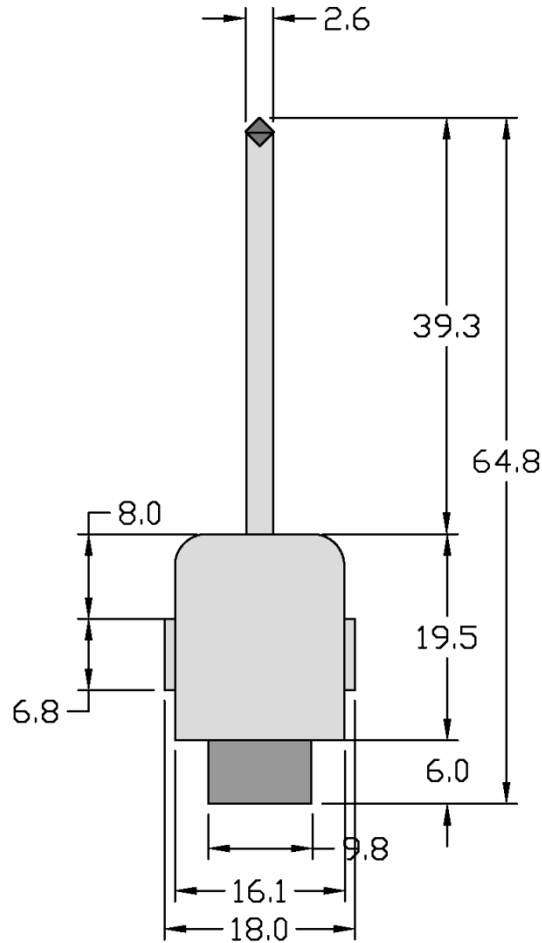

Dimensions in millimeters.

Probe is a cylinder with diameter of ~ 2.5 mm (0.098”).

The thickness of the connector housing is 7.0 mm (0.276”).

## STJ-220 – Specifications

<b>PHYSICAL</b>	Min.	Typical	Max.	Unit
Die Size		0.89 x 0.89		mm
Die Thickness		0.3		mm
Active Area Length		0.79		mm
Active Area Width		0.71		mm
Active Area Thickness	3.0	10.0	20.0	nm
<b>ELECTRICAL</b>				
Sensor Resistance <sup>1</sup>	100	10000	200000	Ω
Recommended Operating Voltage	0.01	5.0	12.0	V
Maximum Operating Frequency <sup>2</sup>		500-1000		MHz
<b>MAGNETIC</b>				
Total Magnetoresistance <sup>3</sup>	50	80	200	%
Non-linearity <sup>4</sup> (+/- 1 G)		0.25	2.0	%
Hysteresis <sup>5</sup> (field range = +/- 1 G)		0.01	0.05	G
Non-linearity <sup>4</sup> (+/- 10 G)		0.50	5.0	%
Hysteresis <sup>5</sup> (field range = +/- 10 G)		0.5	2.0	G
Voltage sensitivity ( $V_{IN} = +12\text{ V}$ )	7	10	13	mV/V/G
Equivalent Field Noise (100 Hz)	2	5	15	nT/Hz <sup>0.5</sup>
Equivalent Field Noise (10 kHz)	0.2	1	5	nT/Hz <sup>0.5</sup>

## STJ-220 – Specifications Notes

1. Sensor resistances can be customized over a wide range of values (10  $\Omega$ -1 M $\Omega$ ) . Please contact Micro Magnetics to discuss your specific needs.
2. The STJ series of sensors have not been tested at frequencies above 100 MHz, but it is generally accepted that this sensor technology will respond to frequencies up to 1-2 GHz.
3. Magnetoresistance is measured over a field sweep range of 100-150 G.
4. Sensor non-linearity is defined as the percentage difference between the measured experimental transfer (resistance versus applied field) curve and the best-fit line to the data. For example, a transfer curve with a linear correlation coefficient of 0.995 would have a non-linearity of 0.5%. Contact Micro Magnetics for more details on how this figure is calculated.
5. Sensor hysteresis is defined as the average (magnetic field) absolute separation between the increasing and decreasing transfer curve data, over the field range of interest. Contact Micro Magnetics for more details on how this figure is calculated.

## STJ-220 – Notes and Handling Instructions

1. The active area of the sensor element is 710 x 790  $\mu\text{m}$ . **Avoid physical contact with the die end of the package.**
2. Each device has a unique ID label.
3. The sensor die is located at the edge of the long probe tip, opposite the connector. Electrical connections are detailed in Figure 1.
4. Please store sensors as they were shipped and in a location which is away from sources of radiated electromagnetic fields (ESD/EMI).
5. Sensors are sensitive to electrostatic discharge (ESD). Be careful to ground tools and your hands when handling the sensors. If possible, be sure to wear grounding straps when handling the sensors.
6. MTJ sensors will fail if subjected to a sufficiently large differential voltage. A good rule-of thumb is to **limit the voltage drop across the sensor element to 12 V** or less at all times.
7. To directly measure MTJ sensor resistance, connect to a constant current source, and measure the voltage drop directly across the SMA connector. In order to limit the voltage drop across the MTJ sensor, initial applied current values should NOT exceed 50  $\mu\text{A}$ . If this amount of current is not sufficient to measure the device resistance, the current may be increased gradually until the sensor voltage is sufficient to make an accurate reading.

---

## STJ-220 – Detailed Description and Notes

The STJ-220 is a bipolar, linear-output magnetic sensor which works on a magnetoresistive principle. Over the specified range of operation, the resistance of this device is approximated by

$$R(H) = R_0(1 + SH)$$

where  $R_0$  is the sensor resistance at zero field,  $H$  is the magnetic field strength in gauss (G) in the sensing direction (indicated on page 1), and  $S$  is the sensor's coefficient of sensitivity, expressed in units of 1/G. The value of  $S$  is provided in the datasheet which is sent with each sensor probe. Note that the value of  $R_0$  can change by up to 25% if the sensor is exposed to large DC magnetic fields. However, this should not greatly affect the field-dependent part of the sensor response.

The sensor consists of numerous small active regions evenly spaced across the sensor die. This effectively guarantees that the sensor will respond to the average field strength which is experienced by the entirety of the die surface.

Making a measurement of field can be accomplished by any method which allows precise measurement of the STJ-220 sensor's electrical resistance, with the following requirement: The sensor has a safe operating differential voltage of no larger than 12 V. **Under no circumstances is the sensor to be subjected to differential voltages of more than 12 V .**

## STJ-220 – Detailed Description and Notes (2)

The simplest way to use the STJ-220 sensor is to apply a constant current across the 5 and 7 of the connector, and measure the corresponding voltage. Alternatively, a constant voltage can be supplied and the current measured to read the sensor resistance.

Another way to use the STJ-220, if the above methods are not feasible, is to build a simple voltage divider with the STJ-220 and a fixed resistor in series. Applying a known voltage to the two-resistor circuit and measuring the voltage across the STJ-220 (or across the fixed resistor) will allow for calculation of the resistance of the STJ-220, and therefore the magnetic field.

### **Testing the STJ-220 Sensor:**

In general, every sensor which is operating properly should behave in the following ways:

1. The resistance of the STJ-220 in small magnetic fields should be within ~25% of the calibrated resistance (this is available on an included datasheet or by contacting Micro Magnetics). Almost always, a sensor which has been damaged has a zero-field resistance which is either infinite (open circuit) or much smaller than the quoted  $R_0$ .
2. A marked change in the resistance of the STJ-220 should be observed when a small magnet (i.e. a refrigerator magnet or even a magnetized tool) is brought to within 0.5-1" of the sensor's active area.

If you are unsure about the condition of an STJ-220 sensor, the above tests are a good first step to take.

### **Technical Support:**

If you require technical support please contact Micro Magnetics at: [support@micromagnetics.com](mailto:support@micromagnetics.com) or (508) 672-4489.